



Shenzhen Beatles Energy Technology Co., Ltd

- Products Catalog of Spread Wings Design Solar
Street Light

Beatles Energy

Global Fortune 500' Choice-Shenzhen Beatles Energy Technology Co., Ltd. is subsidiary of the Beatles Energy Technology (HongKong) Co.,Limited Founded in 2014. The company is integrated enterprise with R&D, production, sales of High Technoly Solar Street Lights ,Solar Garden Lights and other Solar Series products.

Employees 200 people,factory area 4000 square meters, the quantity of technicians and experts reach 15% of all staff, Beatles also collaborate with many famous univerties, built the production-learning and research strategic partnership with them, Unutil now, Beatles already have obtained 14 partents, 11 software Copyright and many certificates, With the standardized management and specialized production, we already passed the ISO9001 quality management system certitication, TUV, BV approvals and CE, RoHS ,SASO,IEC,waterproof certificates etc.

There are many success applications case from different clients in global, we had export to over 100 countries. To meet different market demand, Beatles have different type of solar lights, now the solar lights of Beatles are very popular in Middle East, Africa, Europe, Southeast Asian, Latin America and USA. we also committed to expanding overseas market with more clients in different countries and market, Pursue the management tenet of "Qualit is superior,Service is supreme, Reputation is first", OEM ODM available ,Beatles will sincerely creat and share success with all clients.



New



15° Adjustable Led Panel



Spread Wings Series

Semi-integrated Solar Led Street Lights

- Patent Design
- Semi-Integrated Solar Led Light
- Large Battery Capacity
- Adjustable Led Panel
- High Brightness, 170LM/W
- OEM / ODM Available
- 3 Years Warranty

SPLIT SOLAR STREET LIGHTING ADVANTAGES

1. The split solar lamp is a flexible combination of different components with different capacity.
2. To provide better lighting solutions, our split solar street light can increase the power of solar panels and the capacity of the batteries separately. There is no need for you to worry about the installation of this series.
3. Split solar street light fixtures combine architectural form and versatility to make it an excellent choice for outdoor solar lighting solutions.
4. Split solar street lighting is suitable for all outdoor environment, such as street, highway, village path, garden, factory, etc.

Highlights

- Innovative split structural design, with good heat dissipation performance.
- Adjustable LED module angle , satisfying various road lighting needs.
- Brand new A+ class LifePO4 battery with large capacity, support 10 days working after fully charging.
- Adopting imported high-brightness Bridgelux 3030 and 5050 led chips, lab testing luminous efficiency up to 210lm/w.
- Customzied lighting modes is available, with remote control.
- High conversion efficiency solar panels up to 21%.
- Auto on/ off from dusk to dawn.

Different designs for choose

30W to 120W Led Power Available



2 Led Panels



3 Led Panels



4 Led Panels



5 Led Panels

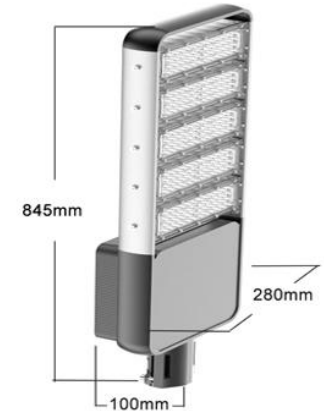
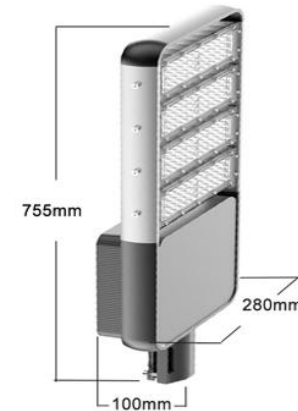
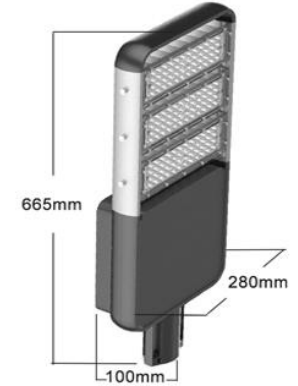

ZC Series Semi-Integrated Solar Street Lights

A split solar led solar street light, composed of led lamp, battery, solar panel, and controller.

Solar Street Light Components



Deep Cycle LifePO4 Battery,
Long Life Cycle > 2000 times

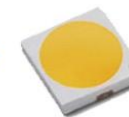

Bridgelux Led Chip,
210LM/watt



MPPT Solar Charge Controller

Solar Panel, Battery And Led Lamp Separated

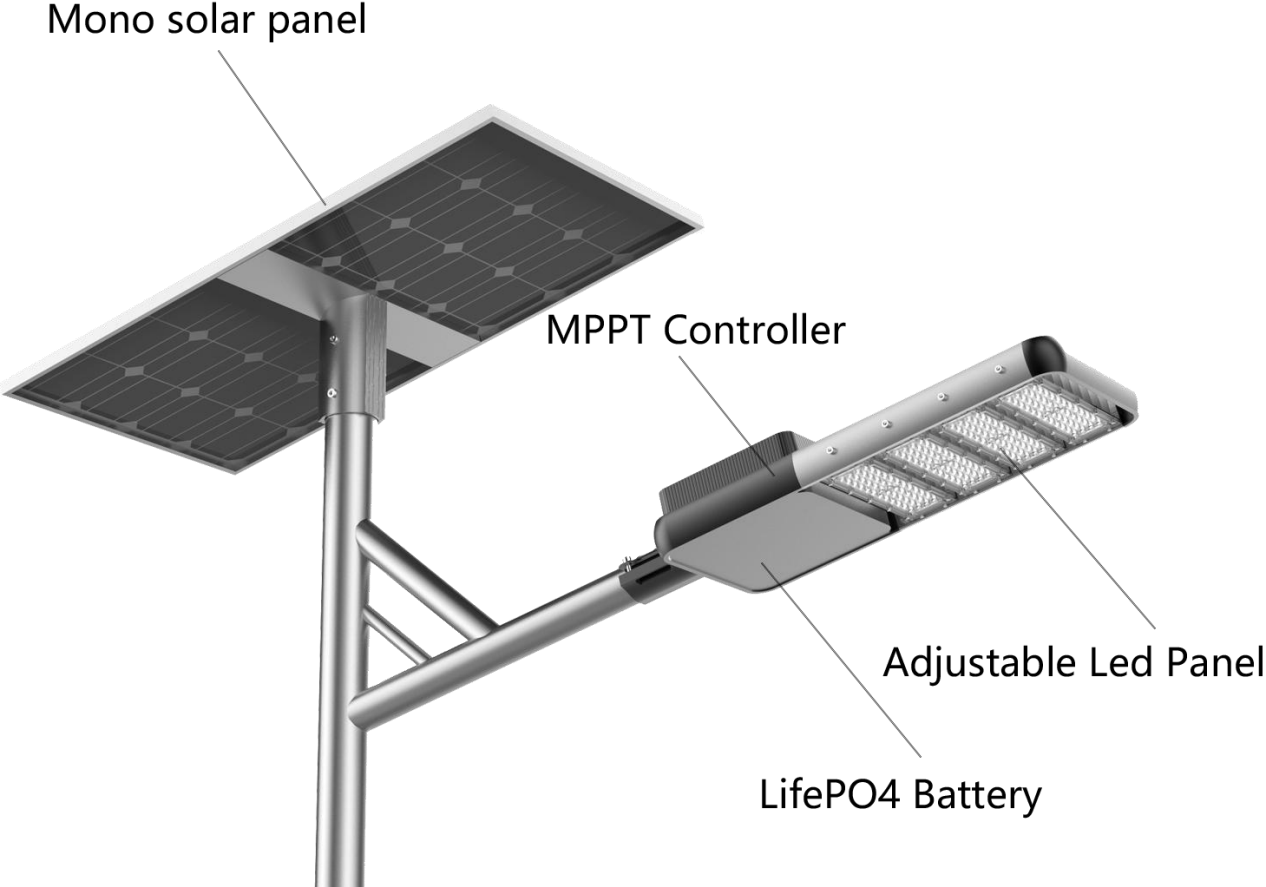

100% Brand New A grade LifePO4 Battery



Brand new A grade battery cell

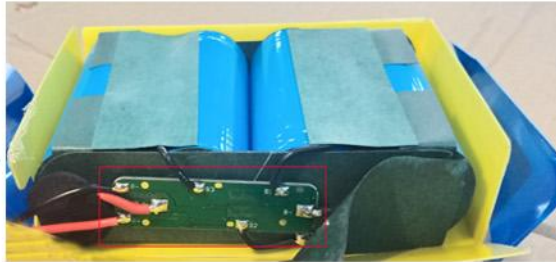

With battery protection board

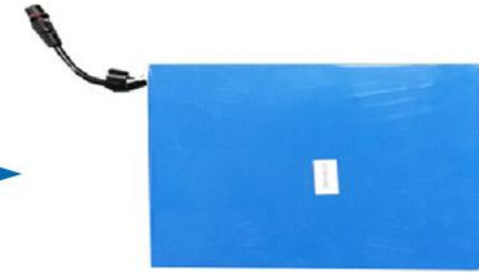

Battery Pack

- >2000 deep cycles.
- 8-10 years lifespan (only 20% loss).
- High-temperature resistance.
- In-built explosion-proof valve and protection board, high safety performance.

High Lumens Led Lamp



210LM/W High Efficiency Bridgelux Led Chip

- 100,000 hours Lifetime
- Bat-wing+Polarized lens, patented lens specially designed, better illumination uniformity improve light effect.



High Efficiency Mono Solar Panel

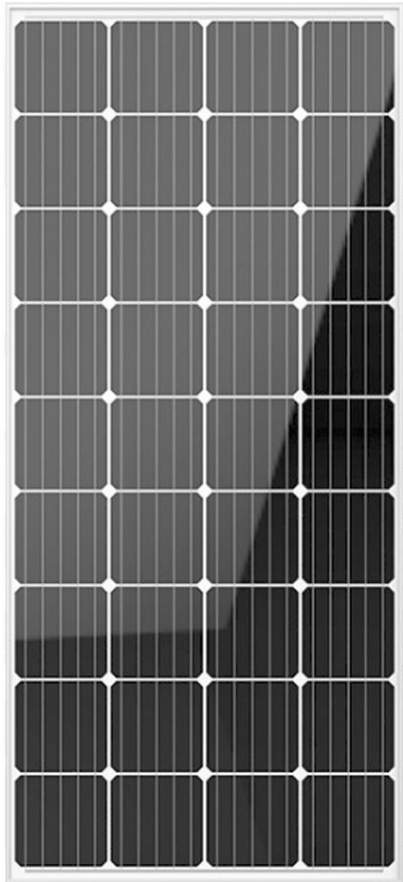

- Monocrystalline Silicon Solar Panel
- >21% Photoelectric conversion efficiency
- 25 years lifespan

*picture just for sample show here

MPPT Controller



- High efficiency conversion
- Intelligent design

*When the power is equal to or less than 40%, the power is automatically allocated to ensure that the duration of the lamp is on.

*When sundays, it can ensure the lighting power.

*When cloudy / rainy days, it can ensure the lighting time.

* With temperature control system, when temperature more than 65°C or lower -25°C, automatic disconnection for protection.

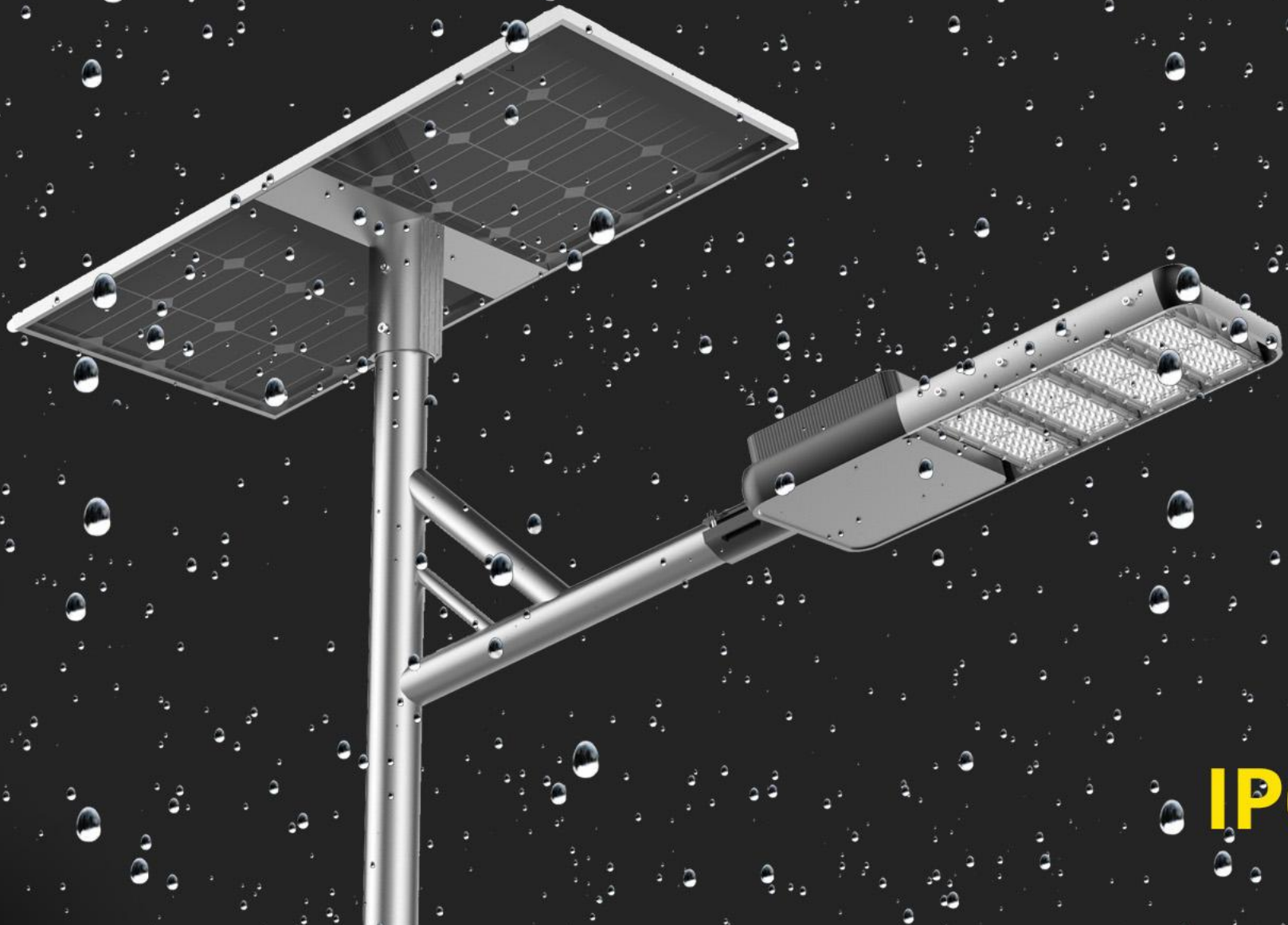

IP66 Waterproof



Support Remote Control

Brightness + / - can be adjusted by yourself.

Lighting dusk to down

5-7 Cloudy / Rainy Days Back Up



Remoter Instruction

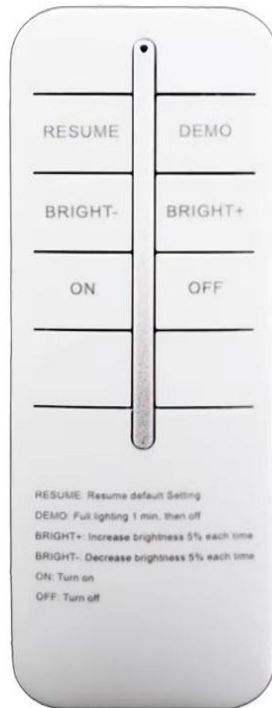

- **RESUME**

Resume default setting

- **DEMO**

Full lighting 1 min, then off

- **BRIGHT-**

Decrease brightness 5% each time

- **BRIGHT +**

Increase brightness 5% each time

- **ON**

Turn on

- **OFF**

Turn off

Easy Installation

Just fix the solar panel and lamp head with screws.

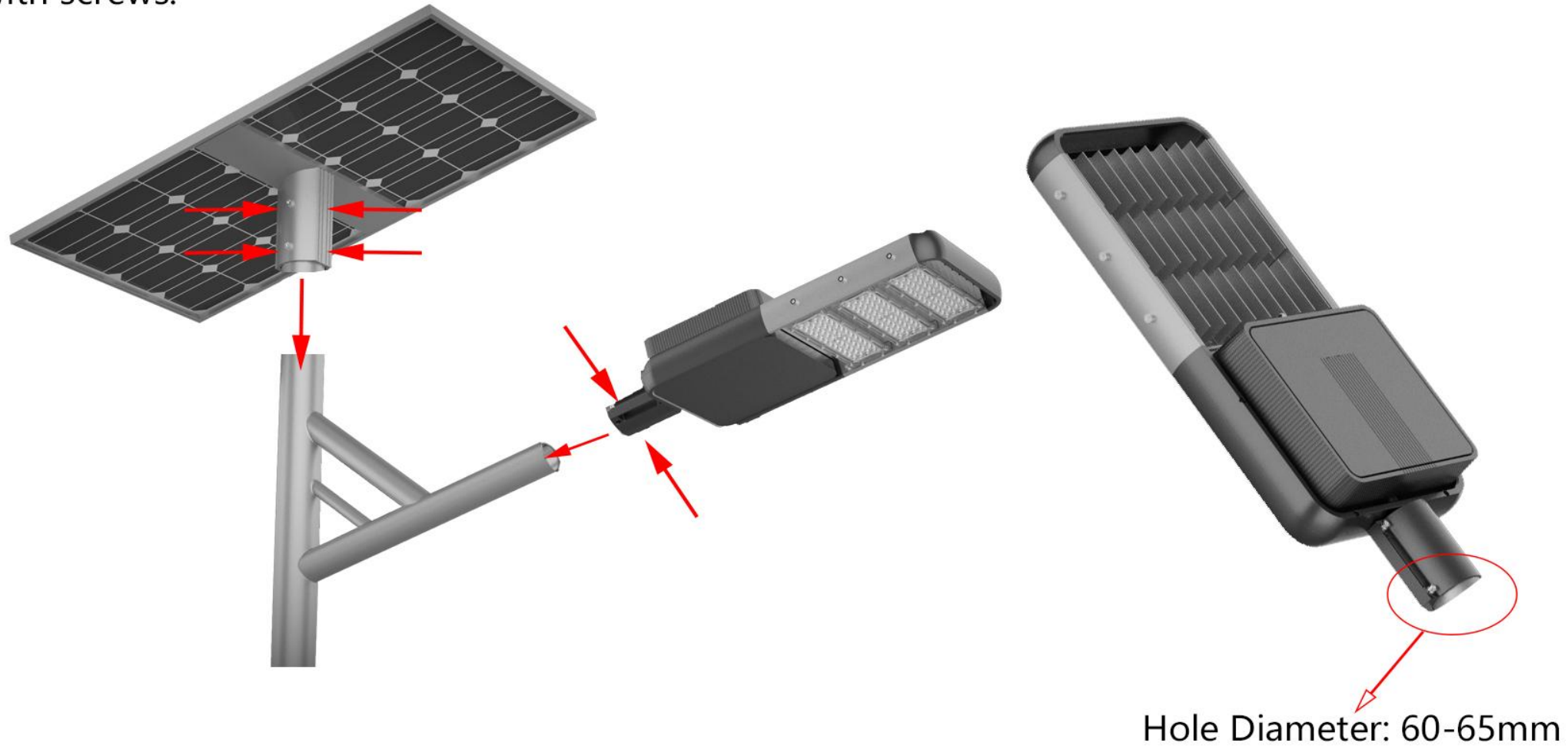

Real Photos of JKC-ZC-60W



Front

Back

Power on

Details



3pcs Led Panel

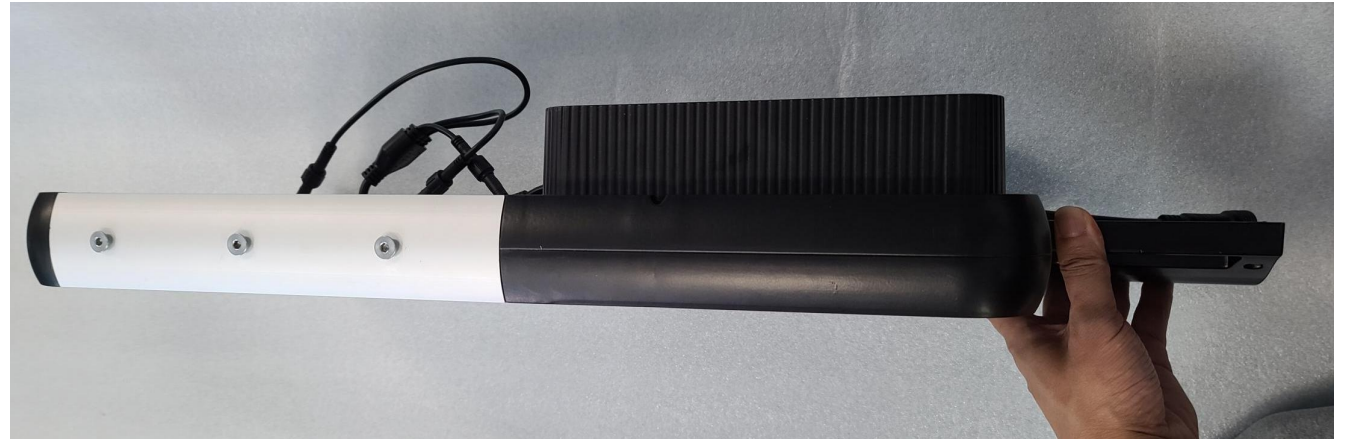

Lateral side

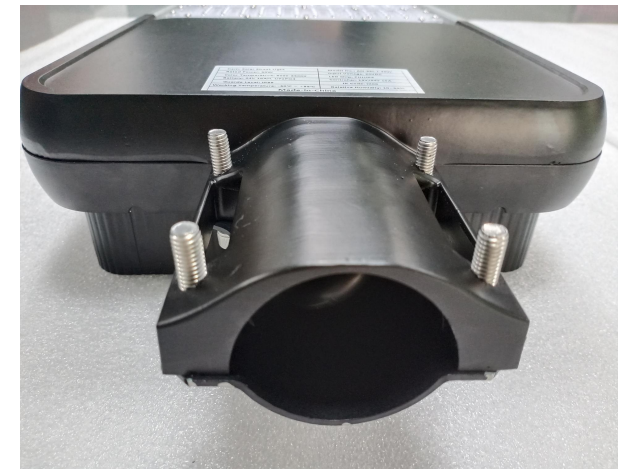

Lamp socket

Specifications (Customized,OEM and ODM are available)

Led Source	30W (96pcs leds)	40W (96pcs leds)	50W (144pcs leds)	60W (144pcs leds)	80W (192pcs leds)	100W (240pcs leds)	120W (240pcs leds)
Mono Solar Panel	18V 40W	18V 50W	18V 65W	18V 80W	18V 100W	18V 130W	18V 170W
LifePO4 Battery	12.8V 384WH	12.8V 384WH	12.8V 576Wh	12.8V 576WH	12.8V 768WH	12.8V 768WH	12.8V 960WH
Color Temperature	2700K-6500K						
Lumen	5100LM	6800LM	8500LM	10200LM	13600LM	17000LM	20400LM
Working Time	12-15hours, 5-7 cloudy/ rainy days						
Charging Time	6-8hours						
IP Rating	IP66						
Mounting Height	4-6m	5-7m	6-8m	7-9m	8-10m	9-12m	10-12m
Space between 2 lamps	10-20m	15-25m	20-30m	20-30m	25-35m	30-40m	34-40m
Warranty	3 years / 5 years						
Package Size	Lamp: 695*300*115mm Solar panel: 610*580*80mm	Lamp: 695*300*115mm Solar panel: 750*580*80mm	Lamp: 695*300*115mm Solar panel: 820*580*80mm	Lamp: 695*300*115mm Solar panel: 1090*580*80mm	Lamp: 785*300*115mm Solar panel: 1290*580*80mm	Lamp: 785*300*115mm Solar panel: 1130*580*80mm	Lamp: 785*300*115mm Solar panel: 1490*580*80mm
Gross Weight	Lamp: 4.6KG Solar panel: 5.2KG	Lamp: 5.2KG Solar panel: 6.3KG	Lamp: 6KG Solar panel: 7.2KG	Lamp: 6.6KG Solar panel: 9KG	Lamp: 7.5KG Solar panel: 11KG	Lamp: 9KG Solar panel: 13.2KG	Lamp: 9.6KG Solar panel: 15.8KG
Standard lighting mode:3 hours 100% brightness+2hours 80% brightness+7hours 25% brightness(customized is available)							

Package

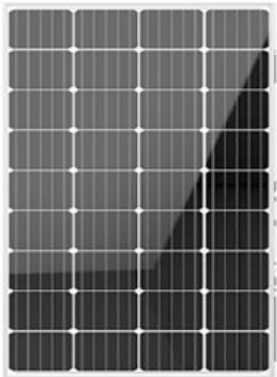

Single Arm



Single Arm Real Case



Double Arm



Double Arm real case

